

A New Approach to Motorcycle Theft Prevention System Based on Arduino Uno

Alex Wenda

Department of Electrical Engineering, Faculty of Science and Technology,
State Islamic University of Sultan Syarif Kasim Riau, Indonesia.

alexwenda@uin-suska.ac.id

Submitted : Sep 24, 2022 | **Accepted** : Sep 28, 2022 | **Published** : Oct 3, 2022

Abstract: The high rate of motorcycle theft was reportedly caused by the negligence of the owner of the motorcycle itself, including forgetting to double lock and leave the key on the motorcycle. This research offers a new approach to prevent motorcycle theft by designing an automatic double lock system through ignition keys, buzzer reminders for left keys, and coordinator points using GPS to track the position of a motorcycle. Automatic dual locks are designed using a solenoid that locks the front and rear disc brakes automatically when the ignition is in the lock position. The buzzer is activated by using a crossbeam sensor consisting of infrared and photodiode mounted on the ignition key slot and seat lock slot which will sound when the user leaves the key in one of the key slots. The Ublox Neo-6m GPS module is used to determine the coordinates of the motorcycle's position if the motorcycle has been stolen. The test results show that the system can work well. User satisfaction testing shows that respondents agree that the system that has been designed has ease of use, is simple and very useful, seen from the average score of usability factor 4.18, simplicity 4.32 and interactivity 4.38 from a scale of 5.

Keywords: Double lock, Arduino Uno, GPS, cross beam Sensor, Solenoid.

INTRODUCTION

The security system on a motorcycle can be categorized into two types, namely a passive security system and an active security system. Passive safety systems are widely used by motorbike owners because they are affordable and cheaper (Savino, Pierini, and Fitzharris 2019). The other system is an active security system, which uses an alarm and all security systems that use electronic devices as a safety module (Ahfas et al. 2019; Sathiyarayanan, Mahendra, and Vasu 2018; Sihombing et al. 2020; Siregar et al. 2019). Along with the development of motorcycle safety technology currently followed by the high level of crime of motorcycle theft, the Central Statistics Agency noted that the theft of motor vehicles known as "*curanmor*" occupies the top place of criminal activity today (BPS 2019).

This is also the case with Riau province, specifically the city of Pekanbaru, which was compiled from the Pekanbaru Police Criminal Investigation Unit for the past 5 years. In 2018 there were 70 motorcycle theft cases with various theft modes including 52 cases with the destruction of ignition key slots using "T" key, 8 cases duplicated ignition key, and 10 cases left keys on the motorcycle. In 2019, 39 cases of theft were reported including 30 cases of destruction of ignition key slots using "T" keys, 4 cases of duplicating keys, and 5 cases of keys left behind. In 2016, there were 47 cases with theft mode including, 39 cases of destruction of ignition key slots using "T" key, and 8 cases of key left behind. In 2020, there were 42 cases of theft mode including 38 cases of destruction of ignition key slots using "T" key, 1 case of duplicating ignition key, and 3 cases of key left behind, and in 2018, there were 32 cases of theft mode by damaging the slot ignition key using "T" key (Polresta 2018). According to Alan Arief, who holds the position of Barbintu at the Pekanbaru Police Criminal Investigation Unit, said that "vehicle theft using the letter" T "key and the key left on the motorcycle only takes no more than a minute. Based on data from the Central Statistics Agency and the Pekanbaru Police Criminal Investigation Unit, we can see that the theft of motorcycle that occur every year by utilizing user negligence (BPS 2019; Polresta 2018).

From the problems mentioned above, several researchers have conducted research to solve the problem of motorcycle theft, by designing systems that are supported by various technologies, including designing smart security system using internet of things (Lestari et al. 2021; Sathiyarayanan et al. 2018), motorcycle anti-theft systems with alarm notification using GSM and GPS (Sihombing et al. 2020; Tombeng et al. 2021; Wirawan and

*Alex Wenda



This is an Creative Commons License This work is licensed under a Creative Commons Attribution-NonCommercial 4.0 International License.

Rahman 2019), security system with SMS Gateway (Saputra and Herlinawati 2017), anti-theft systems motorbike with GPS tracker and Android (Apps 2019; Arta et al. 2021; Siregar et al. 2018), and fingerprint motorcycle safety systems (Furqan et al. 2021).

Based on the data above, it is necessary to have a system that can prevent theft caused by user negligence. The most important thing to be able to prevent motor vehicle theft is to always install a double lock and don't leave the key in the key slot. These two problems are caused by the negligence of users who are usually in a hurry and lazy to install a double lock, besides that some cases often forget to take the key from the lock slot of the motorbike seat when finished inserting a helmet under the motorbike seat. This research proposes a new approach in preventing motorcycle theft by designing an automatic double locking system when the ignition is turned off and to avoid forgetting to take the ignition key, this study uses a crossbeam sensor placed in the key slot, the buzzer will be active when the user leaves the key in the key slot. The design of this system is equipped with a GPS module which is used to determine the coordinates of the position of the motorcycle so that the user can know where the position of the motorcycle has been stolen.

METHOD

In general, the motorcycle theft prevention system has three features; first is double locking the motorcycle automatically, second is ringing the buzzer automatically when the user leaves the key in the key slot and third is determining the coordinates of the motorcycle when the motorcycle is stolen. These three features are illustrated in the block diagram shown in Figure 1.

From Figure 1 it can be seen that the main controller in this system is an Arduino Uno microcontroller (Ramadian and Marlinda 2021) . Two solenoids are used to double lock the front disc and the rear disc of the motorcycle automatically when the ignition is in the lock position. Crossbeam sensor consisting of infrared and photodiode is placed in the ignition slot and seat lock, if the sensor reads a key left in one of the slots which is considered as a barrier between infrared and photodiode, the sensor will send a signal to the microcontroller to activate the buzzer. SIM900 GSM module and Ublox NEO-6M GPS module are used to find the coordinates of the motorcycle's position if the motorcycle has been stolen. A special code that has been set on the microcontroller aims to activate the search for the coordinates of the position of the motorcycle through SMS sent to the SIM900 module which is forwarded to the Ublox Neo-6m GPS module, then the message is returned to the user in the form of a coordinate point link that can be opened through a smartphone in the form of a map. Accu is used to provide power supply to the microcontroller through the DC to DC converter module so that the motorcycle theft prevention system remains active.

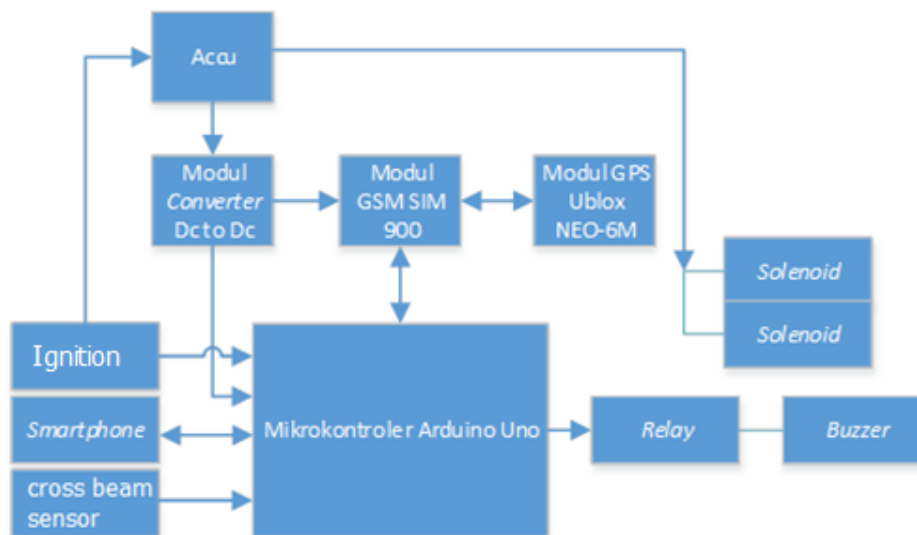
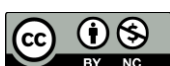

Figure 1 System Design Block Diagram

The automatic double locking system in this study utilizes the ignition switch function of the ignition switch that already exists on the motorcycle. As we know, motorcycle ignition switches consist of 3 conditions; lock, off and on. The lock position is the position where the engine is off and the steering is locked. The off position is the position where the engine is off and the steering is unlocked, and the on position is the position where the engine is running.

Ignition switches that already exist on the motorcycle are given an additional function which is to turn on and off the solenoid function that has been installed on the motorcycle wheel disc. The ignition circuit can be seen in Figure 2 below,

*Alex Wenda



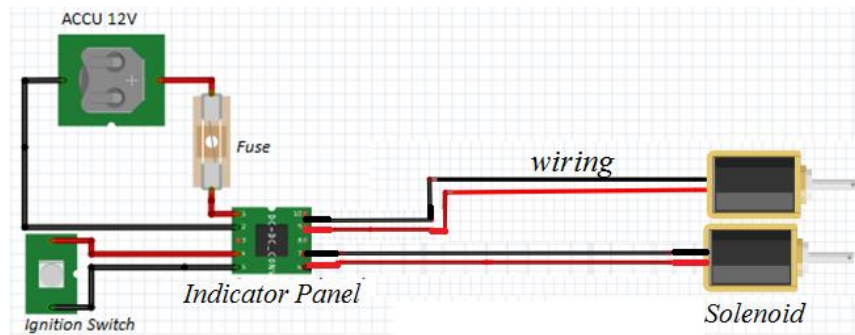

Figure 2 Schematic of the ignition circuit

In the crossbeam sensor design, infrared and photodiode are mounted on the ignition switch that has been perforated on both sides so that later the motorcycle lock can be detected. The output of this crossbeam sensor is a buzzer that will sound when the motorcycle lock is still attached for 3 seconds. This crossbeam sensor circuit can be shown in Figure 3 below,

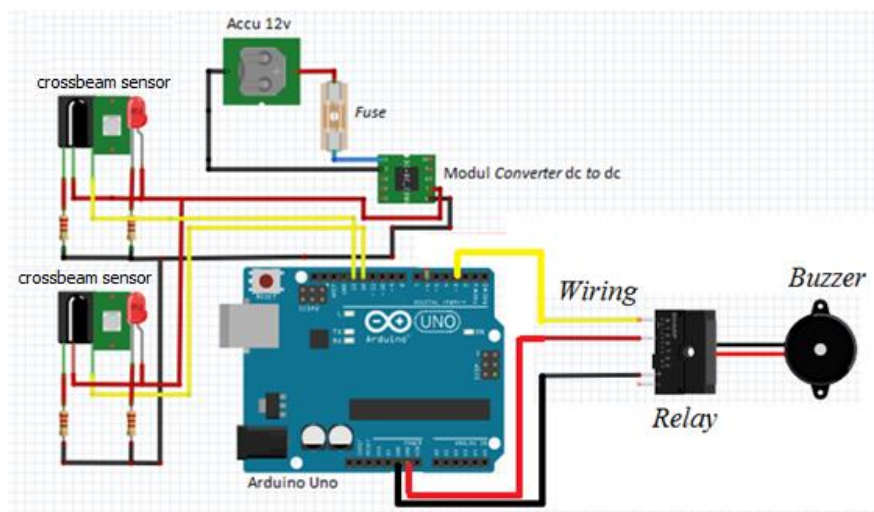

Figure 3 Schematic of a crossbeam sensor circuit

The design of the circuit to find the coordinates of the motorcycle's position using the GSM SIM900 module as an intermediary between the user and the Ublox Neo-6m GPS module. The GPS module which has an Rx pin is connected to Tx on the microcontroller and the Tx pin on the GPS module is connected to Rx on the microcontroller. In this design, both modules have the same Rx Tx pin. For this reason, Rx pin on the GSM module is connected to pin 2 on the microcontroller and pin Tx on the GSM module is connected to pin 3 on the microcontroller. The series of GSM SIM900 modules and GPS modules can be shown in Figure 4 below.

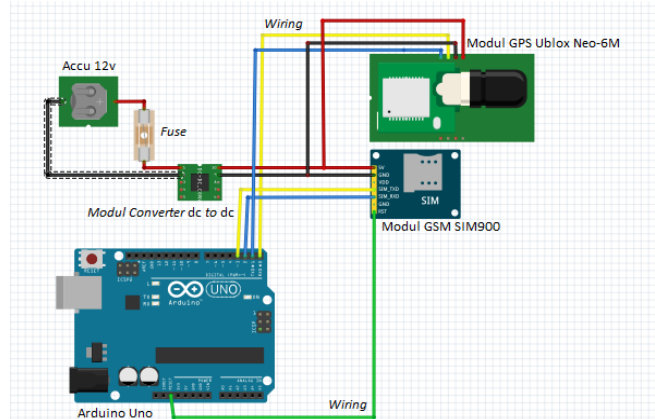

Figure 4 Schematic of GSM Module and GPS Module Circuit

*Alex Wenda



The overall scheme of the system is shown in Figure 5. After all, the components of the system hardware are assembled, the next step is to test to find out whether the system is working as planned or not.

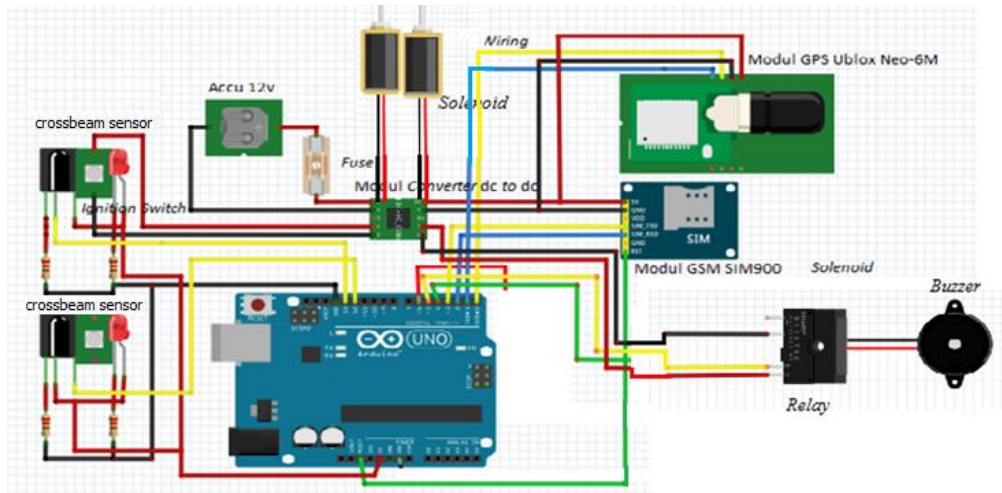

Figure 5 Overall Hardware Designing Scheme

After all the components have been tested and worked well, they are installed on the motorcycle. The installation on a motorcycle follows the scheme shown in Figure 6.

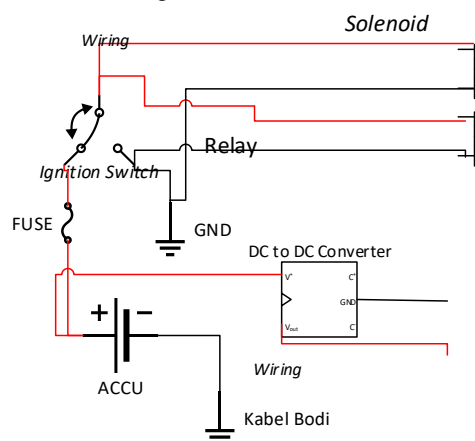

Figure 6 Tool Installation Scheme

In the installation scheme above, the positive voltage (+) sourced from the battery passes through the fuse is connected to the ignition switch to the relay which activates the two solenoids. The negative voltage (-) of the battery is connected to the body of the motorcycle as grounding which will be connected to the GND relay and GND dc converter. The output from the DC to DC converter will be connected to an automatic dual safety device on the motorcycle.

An illustration of installing a motorcycle automatic double lock on the front wheel disc is shown in Figure 7. The position of the solenoid is mounted parallel to the front disc.

*Alex Wenda

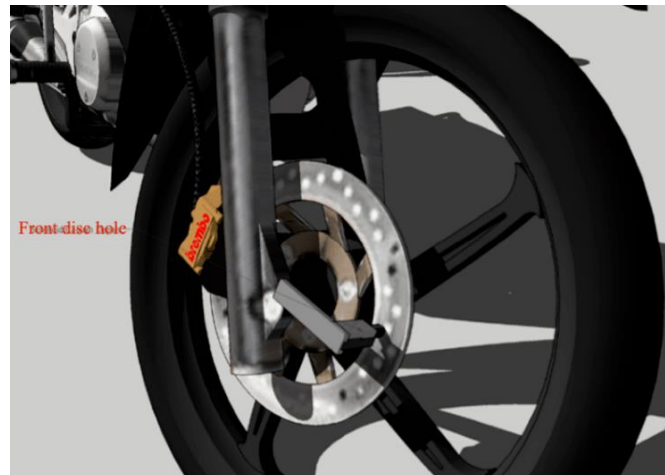

Figure 7 Illustration of Automatic Double Safety on Front Discs

To anticipate the solenoid not being able to enter the disc hole, the front disc is perforated with 4 curved sides which can be seen in Figure 8. The disk disc will be turned into a 4 sided curved shape so that the solenoid does not get stuck when it locks.

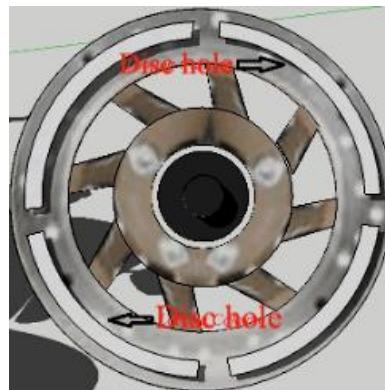

Figure 8 Illustration of Front Disc Holes

The installation of the solenoid on the back disc is shown in Figure 9. The position of the solenoid is mounted parallel to the disk wheel disc that has a large hole so that no turning is needed.



Figure 9 Automatic Double Lock Illustration on Rear Discs

*Alex Wenda



This is an Creative Commons License This work is licensed under a Creative Commons Attribution-NonCommercial 4.0 International License.

The design of software in Arduino is divided into two parts, namely crossbeam sensor programming and GPS system programming. Crosbeam sensor programming aims as an input that is used to activate the buzzer that can inform the user that the key is still attached to the ignition switch and seat lock slot. The flow diagram of the crossbeam sensor programming is shown in the flow diagram of Figure 10.

Programming diagram of the crossbeam sensor starts with initialization, indicating the program is started and the crossbeam sensor will read the input in the form of an ignition key as a barrier between infrared and photodiode. When the ignition is off and is still attached to the ignition switch or seat lock slot, the microcontroller will count for 3 seconds after 3 seconds then the microcontroller will send a signal to the buzzer so the buzzer sounds.

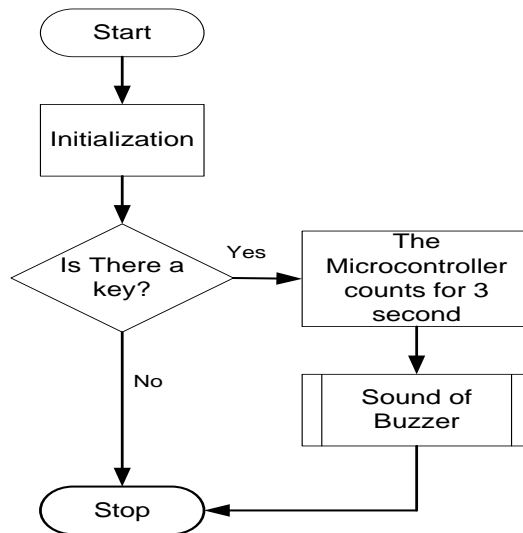

Figure 10 Flowchart Crossbeam sensor programming

Programming on a GPS system is made with the aim that users can communicate with existing devices on a motorcycle. Communication is carried out in the form of a short message sent by the user to the system, then the system will respond to the message by giving a reply in the form of a coordinate point of the motorcycle's position. Figure 11 shows a flowchart of GPS system programming.

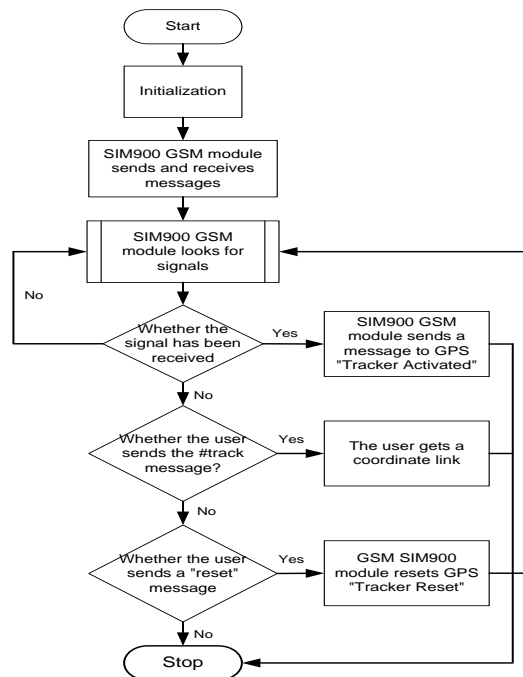
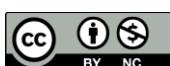

Figure 11 GPS System Programming Flowchart

*Alex Wenda



From Figure 11 it can be explained that the process begins with the device initialization that indicates the program starts working and the GSM SIM900 module sends the message "GPS TRACKER ACTIVATED" to this user meaning the GPS device on the motorcycle has received a signal. The user sends a "track" message so that the device on the motorcycle sends a coordinate link where the current position of the motorcycle is. If the device does not respond to the requested message, the user must send a "reset" message in order for the device to repeat the process from the beginning.

RESULT

The results of designing and installing a solenoid and crossbeam sensor are shown in Figure 12. The solenoid is designed to lock the front and rear disc brakes so that the motor cannot be driven, the position of the solenoid is aligned with the disc brake holes. The front discs need to be modified so that the solenoid can lock perfectly. Crossbeam sensor is placed on the ignition switch and key slot to open the seat. This laying can be adjusted to the model of the motorcycle used.



Figure 12 Position of Sensor and Solenoid crossbeam

Figure 13 shown the result of the design of motorcycle front wheel discs and solenoid position. The disk was perforated by turning into 4 curved sides with a hole diameter of 10 mm, a long curve of 7.6 mm and a spacing of 60 mm each. This is done so that the disc disk is not easily broken and stable.

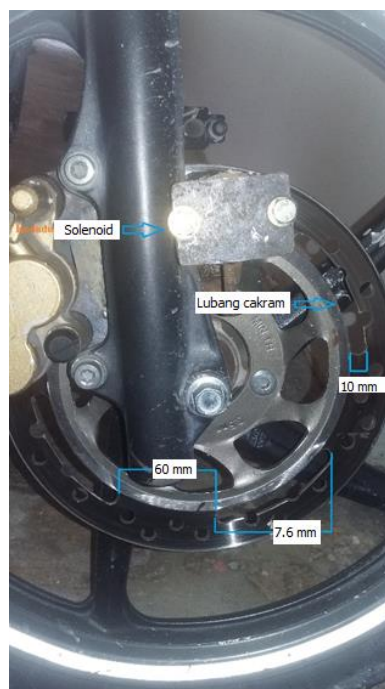

Figure 13 Results of Front Disc Design

*Alex Wenda



As for the rear disc, it doesn't need to be modified because of it already has large and many holes so the solenoid position can lock perfectly.

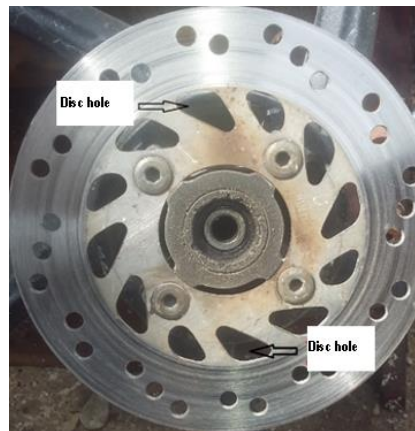

Figure 14 Results of Rear Disc Design

Figure 15 shows the results of testing a double locking system automatically where the ignition switch is in the on position, figure 15 (a), then the solenoid will pull the retaining disk towards the back, shown in Figure 15 (b) and 15 (c) the solenoid does not lock the disc so the motorcycle can be ridden.

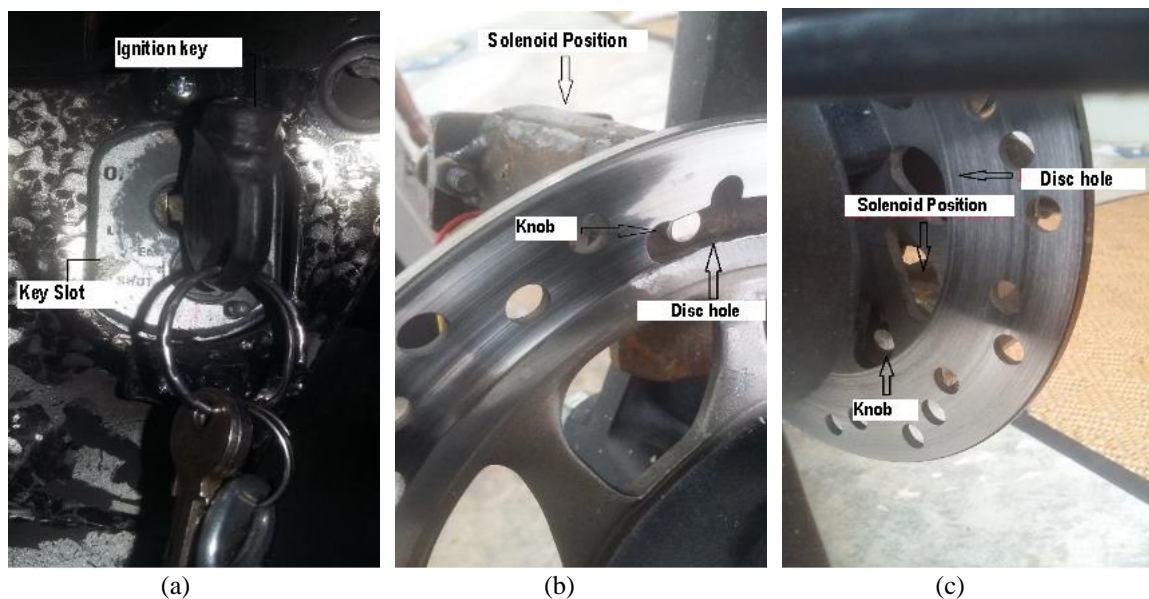

Figure 15 (a) Ignition switch on, (b) Front Disc, (c) Rear Disc

In Figure 16 shows the test results when the ignition switch is in the off position, then the solenoid will release the front wheel and rear wheel disc brakes, so the motorcycle cannot be used for driving.

*Alex Wenda

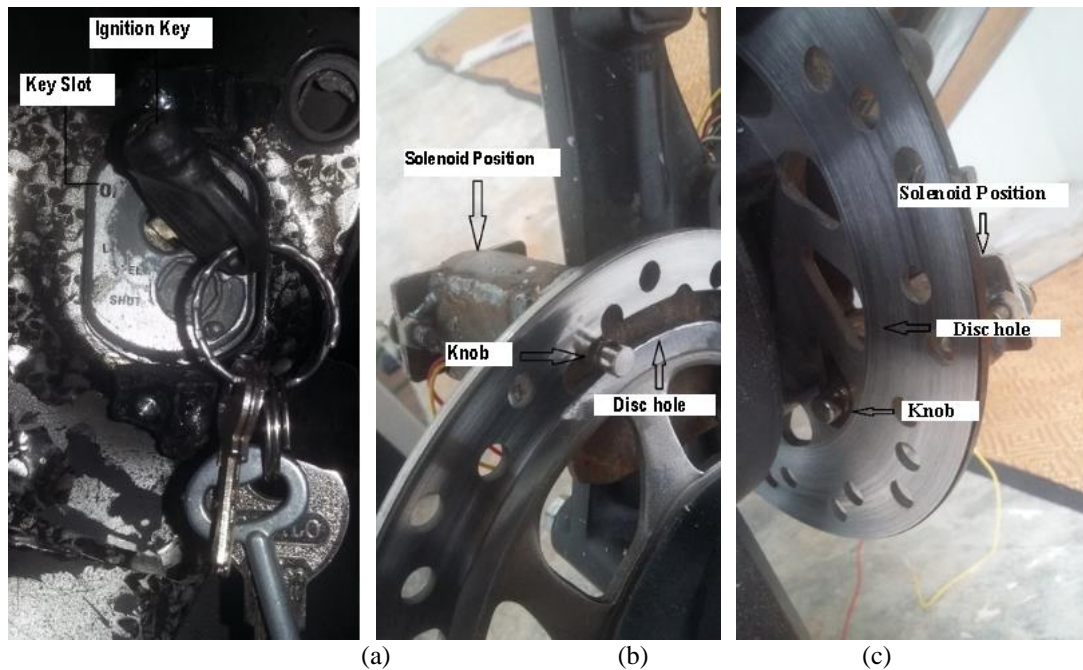

Figure 16 (a) Ignition switch Off, (b) Front Disc, (c) Rear Disc

Crossbeam sensor is tested by inserting a motorcycle key on the ignition switch in the on the condition so the buffer will not sound. Conversely, if the ignition in the key slot is still attached and the ignition switch is off then the key is not taken 3 seconds then the buffer will sound. Likewise, with testing on the seat lock slot, the buffer will sound if the key is not taken within 3 seconds.

Testing of the GSM module has been carried out by installing a jumper cable on the GSM module to the Arduino Uno board. In the GSM module, there is a VCC pin which will be connected to the 5 volt voltage pin, TX TX is connected to pin 7, RX pin is connected to pin 8, and the GND pin is connected to the GND pin on Arduino Uno. When the system is first turned on, the GSM module will search for signals with a fast flashing blue LED. The LED will blink slowly when the signal is registered. The first thing the GSM module does when it gets a signal is to send a message 'GPS SYSTEM ACTIVATED' to the user's mobile number that has been registered. This indicates that the GPS system is active.

To find out the coordinates of the motorcycle the user needs to send the message #track. The system will send a google map link as shown in figure 17.

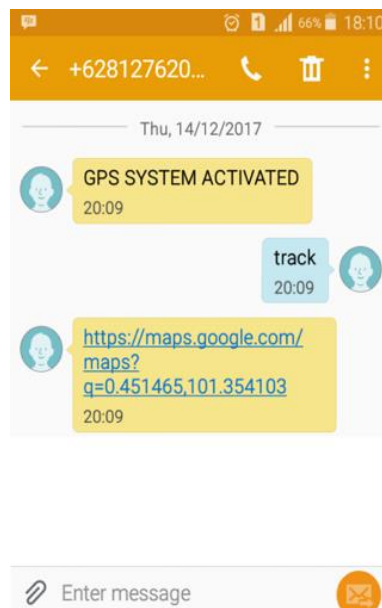

Figure 17 Display message test results on the Mobile User

*Alex Wenda



Testing the Ublox 6m GPS module by installing a jumper cable to Arduino Uno where there are VCC, RX, TX, GND pins. The VCC pin on the GPS module is connected to the 3.3-volt pin, the RX pin on the GPS module is connected to the TX pin, the TX pin on the GPS module is connected to the RX pin, and the GND pin is connected to the GND pin on Arduino Uno. The blue LED on the GPS module will blink every 1 second indicating that a GPS signal has been found.

Figure 18 shows the GPS module test results displayed in the Arduino IDE serial monitor consisting of satellite count, latitude, longitude, MPH speed, and altitude feet which will then be displayed in the Google Maps application.

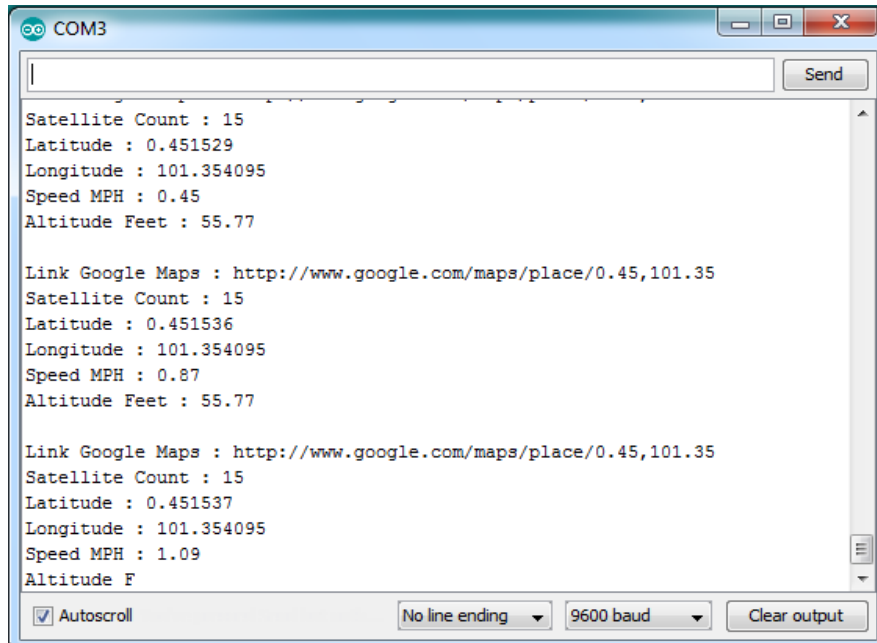

Figure 18 Display of GPS Test Results on Serial Monitor

The SMS which contains the location coordinate link sent by the system is then opened with the Google Map application on the smartphone. Figure 19 shows the results of testing the Google Maps application opened on a smartphone.



Figure 19 Test results Display application on google map

*Alex Wenda

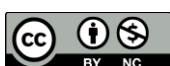

The final part of this sub-section is testing user satisfaction surveys through questionnaires. The fifteen questions in the questionnaire were designed in such a way as to measure the usability, simplicity and interactivity factors of the motorcycle theft prevention system that had been developed. The questionnaire was designed by making a rating scale from poor to very good on a scale of 1 to 5 according to the Likert scale. Before the questionnaire is distributed to respondents, it is tested whether all the questions that have been developed are valid and reliable by testing validity and reliability. Fifty respondents were selected using a random sampling method from UIN SUSKA faculty of science and technology students who own a motorcycle with two front and rear disc brakes. Respondents were asked to operate a system that had been developed then asked to answer the questionnaire.

Table 1 and Figure 21 shows the results of a user satisfaction survey which is shown respondents' assessment scores on a motorcycle theft prevention system. Usability, simplicity, and interactivity factors are used to measure user satisfaction in using a system that has been developed.

Table1 Average scores for each question

<i>Question No</i>	<i>Usability</i>	<i>Simplicity</i>	<i>Interactivity</i>
1	4,31		
2	4,78	4,78	
3	4,31	4,31	
4	3,78	3,98	
5	3,99		
6		4,06	
7		4,27	
8		4,46	
9		4,72	
10	3,91	3,95	
11			4,21
12			4,4
13			4,74
14			4,21
15			4,34

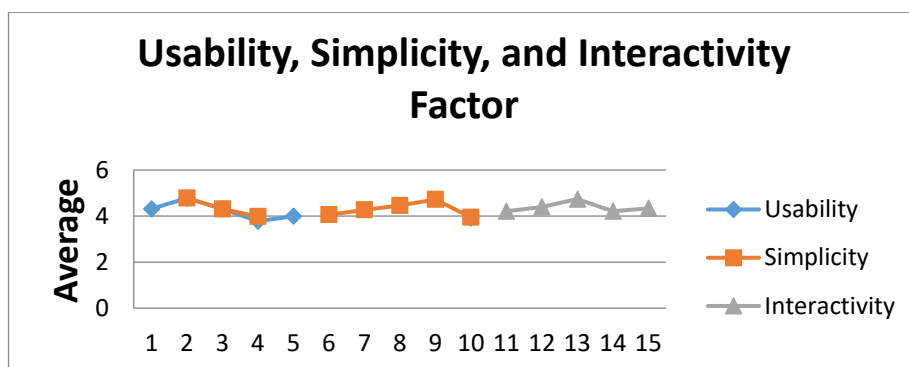
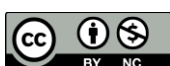

Figure 21 The average score for each question of the survey conducted

DISCUSSION

The results of this research show that the developed system is a new approach to preventing the theft of motor vehicles caused by the negligence of users who constantly forget to leave the motor key and double lock the vehicle. Furthermore, the test results show that this system is easy to use, simple and has a good level of security. Overall, the developed system is sound, but there needs to be an addition of a cover feature on the front of the

*Alex Wenda



solenoid to prevent the solenoid knob from entering the disc hole in the event of an error, placing the barrier sensor position more closed to avoid light interference from the outside so that the sensor reading is more responsive and changes locking system without having to modify the disc.

CONCLUSION

A new approach to motorbike theft prevention systems based on Arduino Uno has been successfully developed. The automatic dual locking system can ensure that the motor will always be double locked when it is parked. The buzzer will activate after three seconds if there is still a key in one of the motorcycle's key slots. The determination of location points can be activated if the motorcycle has been stolen. User satisfaction test results show that the user is satisfied with the system that has been developed.

REFERENCES

- Ahfas, A., D. Hadidjaja, S. Syahririni, and A. Wicaksono. 2019. "Sound Indicators as Safety of Motorcycle." in *Journal of Physics: Conference Series*. Vol. 1402. IOP Publishing Ltd.
- Apps, Android. 2019. "ANTI-THEFT PROTECTION OF VEHICLE USING GPS TRACKER & ANDROID APPS." 19(2):78–83.
- Arta, Yudhi, Evizal Abdul Kadir, Ari Hanggara, Des Suryani, and Nesi Syafitri. 2021. "Implementation of Motorcycle Monitoring Using Bluetooth with an Android-Based Microcontroller Using Arduino." Pp. 155–64 in *Proceedings of International Conference on Smart Computing and Cyber Security*, edited by P. K. Pattnaik, M. Sain, A. A. Al-Absi, and P. Kumar. Singapore: Springer Singapore.
- BPS. 2019. *Statistik Kriminal 2018*.
- Furqan, Mhd, Muhammad Ikhsan, Abdul Halim Hasugian, and Muhammad Ridzki Hasibuan. 2021. "Http://Infor.Seainstitute.Org/Index.Php/Infokum/Index INFOKUM Is Licensed under a Creative Commons Attribution-Non Commercial 4.0 International License (CC BY-NC 4.0) Application Of Security System Of Motorcycle Used Fingerprint Optical Sensor And Vibration Sensor With Fuzzy Logic Based On Arduino Uno R3." *JURNAL INFOKUM* 10(1).
- Lestari, Ninik Sri, Herawati, Andrew Ghea Mahardika, Taufik Rachman, Hendi Suhendi, Asep Hilmi Mutaqin, and Rahmad Hidayat. 2021. "Internet of Things Based Motorcycle Monitoring Application Development." in *Journal of Physics: Conference Series*. Vol. 1933. IOP Publishing Ltd.
- Polresta. 2018. *Statistik Kriminal Satuan Reserse Dan Kriminal Kota Pekanbaru 2018*.
- Ramadian, Angga Putra, and Linda Marlinda. 2021. "Design of Automatic Hand Sanitizer Based on Arduino Uno Microcontroller." *Sinkron* 6(1):157–67. doi: 10.33395/sinkron.v6i1.11174.
- Saputra, Oka Kurniawan, and Herlinawati. 2017. "Rancang Bangun Sistem Keamanan Kendaraan Bermotor Berbasis GPS (Global Positioning System) Dan Koneksi Bluetooth." *Electrician* 11(3):9.
- Sathiyarayanan, M., S. Mahendra, and R. B. Vasu. 2018. "Smart Security System for Vehicles Using Internet of Things (IoT)." Pp. 430–35 in *2018 Second International Conference on Green Computing and Internet of Things (ICGCIoT)*.
- Savino, Giovanni, Marco Pierini, and Michael Fitzharris. 2019. "Motorcycle Active Safety Systems: Assessment of the Function and Applicability Using a Population-Based Crash Data Set." *Traffic Injury Prevention* 20(4):406–12. doi: 10.1080/15389588.2019.1594795.
- Sihombing, P., I. S. Daulay, S. Efendy, and I. Syarif. 2020. "Motor Vehicle Security Using Microcontroller, GPS and Android as Innovation to Prevent Motor Thieves." in *Journal of Physics: Conference Series*. Vol. 1566. Institute of Physics Publishing.
- Siregar, B., S. Efendi, C. Setiawan, and F. Fahmi. 2019. "RFID Wristband for Motorbikes Real-Time Security System." Pp. 116–19 in *2019 3rd International Conference on Electrical, Telecommunication and Computer Engineering (ELTICOM)*.
- Siregar, Baihaqi, Chairul Saleh Nasution, Dani Gunawan, Sawaluddin Sawaluddin, Ulfi Andayani, and Fahmi Fahmi. 2018. "Security Device for Motorcycle Using Smartphone Android with Promini." in *Journal of Physics: Conference Series*. Vol. 1028. Institute of Physics Publishing.
- Tombeng, M. T., D. D. P. Purwadaria, I. S. Hwang, and A. T. Liem. 2021. "Design of Android-Based Motorcycle Security System Using Face Detection and GPS Tracking." Pp. 1–5 in *2021 3rd International Conference on Cybernetics and Intelligent System (ICORIS)*.
- Wirawan, Nanda Tommy, and Sepsa Nur Rahman. 2019. "Message Gateway-Based Control System for Parents on the Use of Motorcycle Vehicles in Young Adolescents." *Sinkron* 4(1):83. doi: 10.33395/sinkron.v4i1.10178.